



BIG JOBS, LOW COST

Purpose-built and optimized for HDD, the **DECKHAND[®]LT** offers a safe and cost-effective way to handle drill pipe and tooling on the job site, increasing efficiency and reducing risk to crew.

The **DECKHAND[®]LT** with our Directional Drilling LT (DDL) Arms gives you precision in loading drill rigs, positioning pipe, and moving drill rod and tooling around the work area. Entry or exit side, you're in the driver's seat with total control from the excavator cab—and out of harm's way.

DECKHAND[®]LT features the following:

- » 360-degree continuous rotation for maximum versatility
- » In-cab display for monitoring and easy adjustments
- » Load hold valves guarantee grip regardless of hydraulic pressure - meaning no dropped pipe!
- » Powered by the excavator's auxiliary circuit
- » Durability and precision you've come to expect, in a cost-effective package

**SAFER, FASTER, BETTER.
OUR TOOLS IN YOUR HANDS GET THE JOB DONE.**



Learn more at
LAVALLEYINDUSTRIES.COM



▲ **DECKHAND® LT PRODUCT SPECS:**

- Part Number: 8400
- Model Number: DHLT
- Excavator Wt Class: 20-36 METRIC TON
- Supply Pressure: 3,000 PSI / 207 BAR
- Standard Recommended Flow: 25 GPM / 95 LPM
- Max Flow: 30 GPM / 114 LPM
- Min Flow: 20 GPM / 76 LPM
- Main Beam can tilt up to 18° in either direction
- Main Beam Size (inches): 6x6
- Capacity: 10,000 LBS / 4,536 KG
- Weight: 2,137 LB / 969 KG
- Overall Dimensions (inches): 84L x 37W x 54H

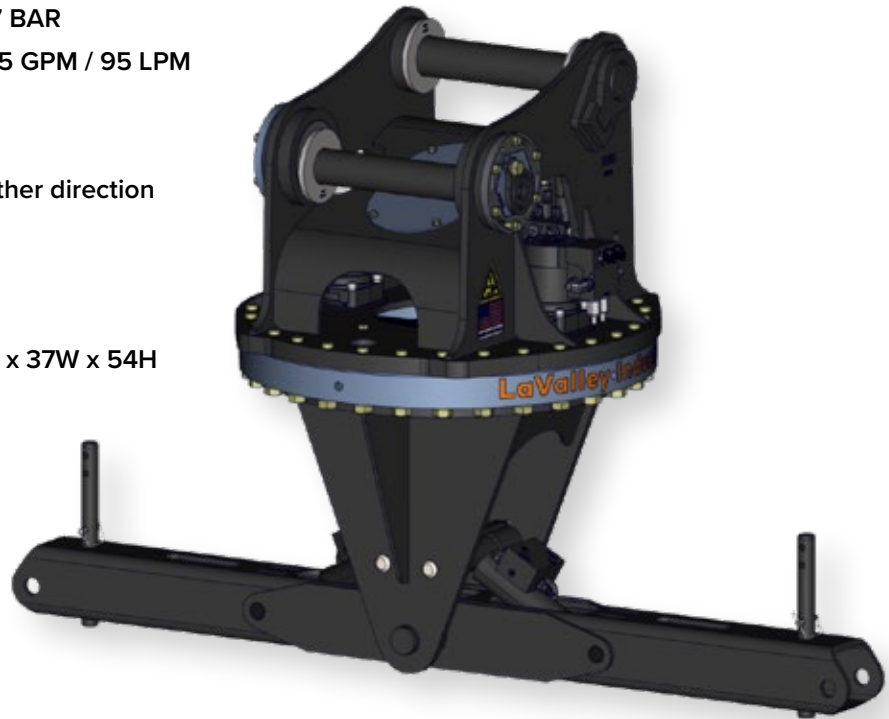

DIRECTIONAL DRILLING LT ARMS



ARM SPECS

Model Number: DDLT
Part Number: 8430
Main Beam Size (in.): 6x6
Weight: 220 LB / 100 KG
Capacity (set of arms): 10,000 LB / 4,536 KG
Pipe Diameter: 4.5" to 9"

These Directional Drilling Arms have been specifically designed and optimized for use with **DECKHAND® LT** —offering you the same durability and precision in a cost-effective package!