

DECKHAND® XL

The DECKHAND® XL handles the largest and heaviest pipe gently and safely, while outperforming all existing pipe handling methods.

- Head unit mounts to any brand of excavator in the 60-75 metric ton class
- Designed to meet ASME Below-The-Hook Lifting Standards
- Load locking valves hold pipe securely, regardless of hydraulic pressure
- 360° Continuous Rotation
- Tilts up to 14°
- Shifts pipe side to side up to 7.5" in either direction
- Requires auxiliary hydraulic circuit on excavator
- In-cab display allows operator to safely monitor and adjust all functions, working parameters, and hydraulic settings from inside the excavator
- Optional stick-mounted camera allows operator to see in even the most difficult spaces

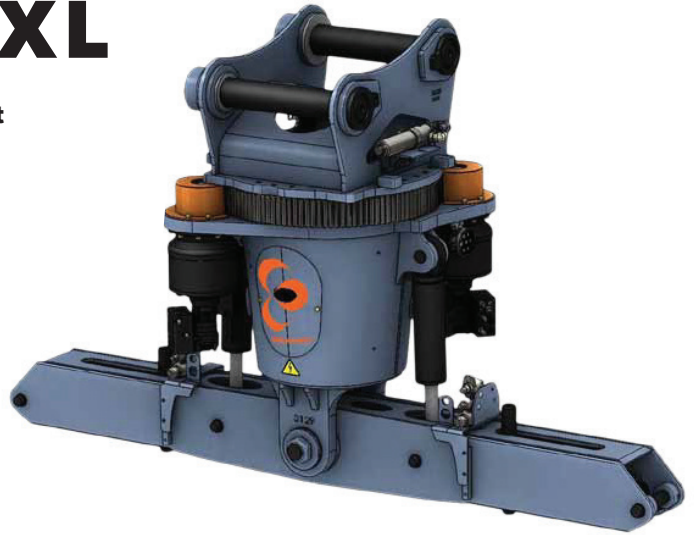

DECKHAND® XL HEAD UNIT

Part Number	2807
Model Number	DHXL
Excavator Wt Class	60-75 METRIC TON
Supply Pressure	3,200 PSI / 221 BAR
Standard Recommended Flow	35 GPM / 132 LPM
Max Flow	40 GPM / 151 LPM
Min Flow	30 GPM / 114 LPM
Main Beam Size (inches)	10X10
Capacity	50,000 LBS / 22,680 KGS
Weight	4,177 LBS / 1,875 KGS
Overall Dimensions	117L X 40W X 70H (IN) / 297L x 102W x 178H (CM)
Shipping Stand P/N	2605
Shipping Weight w/ Stand	4,565 LBS / 2,071 KGS

DECKHAND® COMPETITIVE ADVANTAGES

The DECKHAND® by LaValley Industries offers a long list of advantages versus traditional pipe handling methods in terms of safety, operational efficiency, and total project costs:

	STRAPS & CHAINS	VACUUM LIFTS	DECKHAND®
MAN POWER	2-4 PEOPLE	1-3 PEOPLE	1 PERSON
Both straps/chains and vacuum lifts require extra manpower for positioning pipe.			
OVERALL SAFETY	POOR	FAIR	EXCELLENT
DECKHAND® eliminates workers in the vicinity of lifted pipe. No matter what the weather conditions, DECKHAND® offers positive grip and total control of pipe, unlike vacuum lifts.			
LOAD HOLDING	POSITIVE	CAN DROP LOAD	POSITIVE
Load hold valves on DECKHAND® arms ensure that pipe never drops, regardless of hydraulic pressure.			
LOAD CONTROL	POOR	POOR	EXCELLENT
DECKHAND® offers control of pipe in all directions. Vacuum lifts are free-swinging in one direction and cannot tilt pipe.			
LOAD PLACEMENT	GROUND PERSONNEL REQUIRED	FAIR	EXCELLENT
DECKHAND® offers powered control of pipe in all directions, which allows for fast, accurate pipe placement without any ground assistance.			
PRODUCTIVITY	LOW	MODERATE	HIGH
Straps/chains and vacuum lifts require multiple workers, while the DECKHAND® requires just one operator. Vacuum lifts are slower than DECKHAND® at moving and positioning pipe.			
OFF-CENTER LIFTS	NO	NO	YES
DECKHAND® can lift pipe off-center per operating limits.			
TOTAL OWNERSHIP COST	MEDIUM	HIGH	LOW
DECKHAND®s robust design ensures a long lifespan and nominal maintenance costs.			
LABOR COST	2-4 PEOPLE	1-3 PEOPLE	1 PERSON
DECKHAND® also increases pipe handling production vs. other methods.			
PIPE & EQUIPMENT DAMAGE	HIGH	MEDIUM	LOW
Vacuum lifts can drop pipe unintentionally or swing pipe into objects, causing pipe and/or equipment.			
MAINTENANCE COSTS	LOW	HIGH	LOW
DECKHAND® requires weekly greasing and occasional wear pad replacement. Vacuum lifts require suction pads to be replaced when torn or every 200 hours, and filters to be replaced daily in certain weather conditions (diesel engine also requires daily fueling and maintenance).			
INSURANCE COSTS	HIGH	MEDIUM	LOW
With DECKHAND®, fewer ground workers equals lower insurance costs.			