

MAT ARM

Designed to precisely handle and position wood or composite mats up to 40' long and 12" thick using the DECKHAND S, DECKHAND, and DECKHAND 5HP models

- Utilizes interchangeable tines to handle 3', 4', 5' and 8' mat widths
- Sensors allow operator to monitor arm grip status while moving mat
- Load locking valve system ensures mat is never dropped
- Mats can be lifted from an off-center position
- Mats can be placed with precision under total operator control
- Positive grip allows dirt and debris to be shaken off mats during removal

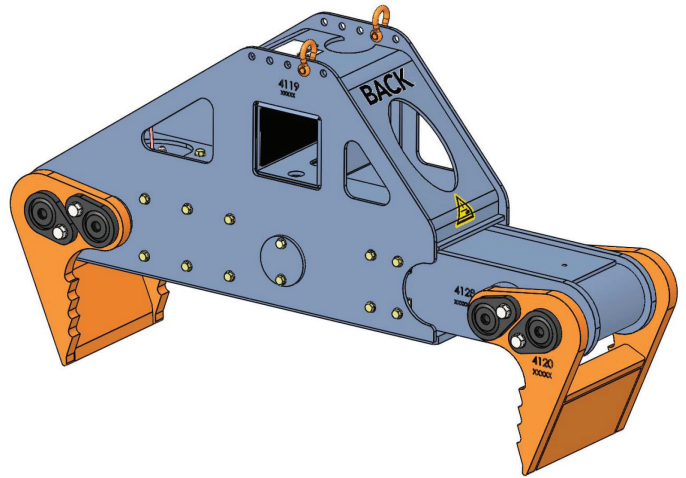

DECKHAND MAT ARM MA SPECIFICATIONS

Part Number	4067
Model Number	MA
Main Beam Size (inches)	6x6
Capacity (per two arms)	16,000 LB / 7,258 KG
Weight	1,000 LB / 454 KG
Shipping Crate P/N	4228
Shipping Dimensions	64L x 64W x 51H IN / 163L x 163W x 130H CM
Shipping Weight (arm set with crate)	3,215 LB / 1,458 KG

MAT ARM LARGE

Designed to precisely handle and position wood or composite mats up to 40' long and 12" thick using DECKHAND L

- Utilizes interchangeable tines to handle 3', 4', 5' and 8' mat widths
- Sensors allow operator to monitor arm grip status while moving mat
- Load locking valve system ensures mat is never dropped
- Mats can be lifted from an off-center position
- Mats can be placed with precision under total operator control
- Positive grip allows dirt and debris to be shaken off mats during removal

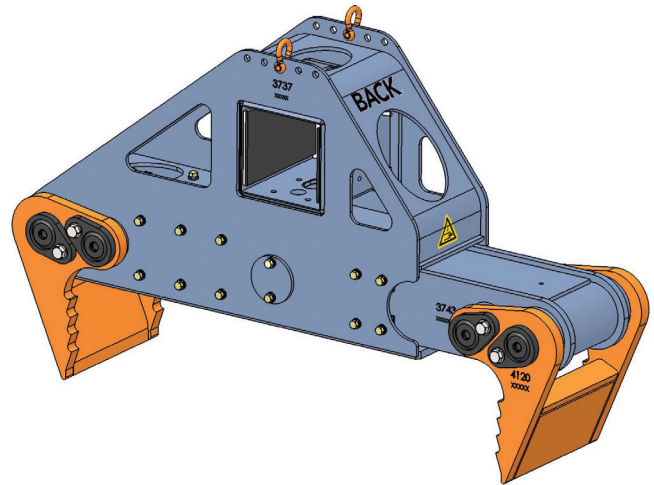

DECKHAND MAT ARM LARGE MAL SPECIFICATIONS

Part Number	3738
Model Number	MAL
Main Beam Size (inches)	8x8
Capacity (per two arms)	16,000 LB / 7,258 KG
Weight	1,043 LB / 473 KG
Shipping Crate P/N	4228
Shipping Dimensions	64L x 64W x 51H IN / 163L x 163W x 130H CM
Shipping Weight (arm set with crate)	3,300 LB / 1,500 KG